

USN

--	--	--	--	--	--	--	--	--	--	--	--	--	--	--	--	--	--	--	--	--

10ME52

Fifth Semester B.E. Degree Examination, July/August 2022

Design of Machine Elements – I

Time: 3 hrs.

Max. Marks:100

- Note: 1. Answer any FIVE full questions, selecting at least TWO questions from each part.
2. Use of Design Data hand book is permitted.
3. Missing data if any may be suitably assumed.*

PART – A

- 1 a. Define machine design. (02 Marks)
- b. A shaft of diameter 50 mm is subjected to an axial tensile load of 15 kN, a pure torque of 1000 Nm and bending moment of 750 Nm. Calculate the principal stresses. (08 Marks)
- c. Fig.Q1(c) shows a wall bracket subjected to a load of 36 kN. Find the width and depth of rectangular cross section taking the depth as three times the width. Yield stress of the material of wall bracket is 328 MPa. Adopt factor of safety as 2.5.

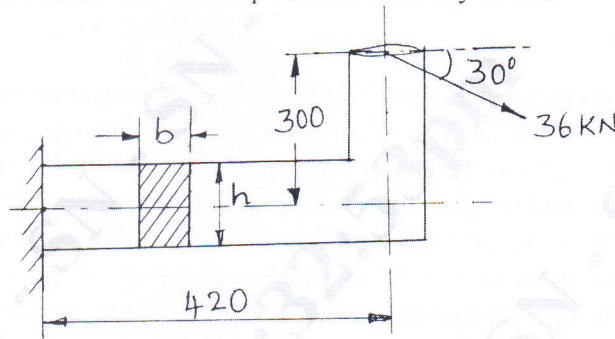

Fig.Q1(c)

(10 Marks)

- 2 a. A steel shaft is subjected to a bending moment of 9 kN-m and a twisting moment of 12 kN-m. The yield strength of steel is 360 MPa. If a factor of safety of 2 with respect to failure is specified, determine the permissible diameter of the shaft according to:
 - (i) Maximum shear stress theory of failure.
 - (ii) Maximum distortion energy theory of failure. (08 Marks)
- b. Find the diameter of the hole in Fig.Q2(b) if the stress concentration factor at the hole is to be same as at the fillet.

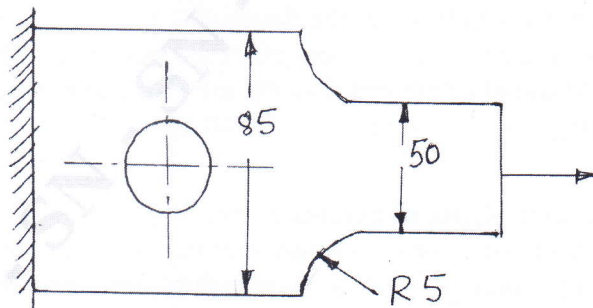

Fig.Q2(b)

(06 Marks)

- c. Determine the diameter 'd' of a round rod 200 mm long fixed at the bottom end and free at the other end to sustain a weight of 5 kN falling on to the rod axially from a height of 40 mm. Yield strength of material of the rod is 324 MPa. Adopt a factor of safety as 2.5.

(06 Marks)

Important Note : 1. On completing your answers, compulsorily draw diagonal cross lines on the remaining blank pages.
2. Any revealing of identification, appeal to evaluator and /or equations written eg, 42+8 = 50, will be treated as malpractice.

- 3 a. A simply supported beam has a concentrated point load at its centre. The load fluctuates from 'P' to '4P'. The span of the beam is 500 mm and is of circular cross section with a diameter of 60 mm. The yield stress is 390 MPa and endurance limit stress is 260 MPa. Surface correction factor is 0.85. Load and size correction factor is 1. Considering factor of safety as 1.5, calculate the value of load 'P' that can be applied. (08 Marks)
- b. A round bar is subjected to the following variable loads.
Torque varying from 2 kNm to 5kNm.
Bending moment varying from 10 kNm to 12 kNm.
Calculate the diameter of the bar if it is made of C-40 steel for which yield stress is 324 MPa. Adopt a factor of safety as 2.5. $\sigma_{-1} = 309$ MPa. (12 Marks)
- 4 a. Explain various types of stresses in threaded fasteners. (06 Marks)
- b. Estimate the maximum Wrench torque which can be applied in tightening a 20 mm bolt if the shear stress in the body of the bolt is not to exceed 140 MN/m^2 . Outside bolt diameter = 20 mm, root diameter = 16.72 mm, thread section has 60° included angle, pitch = 2.5 mm, effective friction radius under nut = 12 mm, thread and collar friction coefficient estimated at 0.10. (14 Marks)

PART – B

- 5 A power transmission shaft 1300 mm long is supported in bearings at its extreme ends A and B. A power of 30 KW is received at 500 rpm through a gear drive located at 400 mm to the right of the left extreme end of the shaft. The gear mounted on the shaft has a pitch diameter of 300 mm and weighs 800 N. This gear receives power from a gear located exactly behind. The power is delivered through a belt drive located 500 mm to the left of the right bearing. The pulley mounted on the shaft has a diameter of 400 mm and weighs 1000 N. The belt is directed towards the observer below the horizontal and inclined at 45° . Ratio of belt tensions is 3. Material of the shaft is C-40 steel. Assuming a factor of safety of 2.5 and loading to be with minor shocks, determine the diameter of the solid shaft. (20 Marks)
- 6 a. A flange coupling used to connect two coaxial shafts of diameter 80 mm to transmit 60 KW at 200 rpm, 6 bolts of $M14 \times 1.5$ (core area of 125 mm^2) on a bolt circle diameter of 210 mm are used to fasten the flanges. If the flange thickness is 20 mm and the hub diameter is 145 mm, determine:
(i) Shear stress induced in the shaft
(ii) Shear stress induced in the bolt
(iii) Shear stress induced in the flange (10 Marks)
- b. Design a knuckle joint to connect two mild steel rods. The joint has to transmit a tensile load of 80 kN. Material of the rods has the following allowable stresses:
 $\sigma_t = 80$ MPa, $\sigma_c = 120$ MPa, $\tau = 40$ MPa (10 Marks)
- 7 a. Explain different types of failures in riveted joints. (04 Marks)
- b. A double riveted double cover butt joint in plates 20 mm thick is made with 25 mm diameter rivets of 110 mm pitch. The permissible stresses are $\sigma_t = 120$ MPa, $\sigma_c = 150$ MPa, $\tau = 100$ MPa. Find the efficiency of the joint taking the strength of the rivet in double shear as twice than that of single shear. (08 Marks)

10ME52

- c. Suggest a suitable size for a welded joint loaded as shown in Fig.Q7(c). Assume $\tau = 90$ MPa.

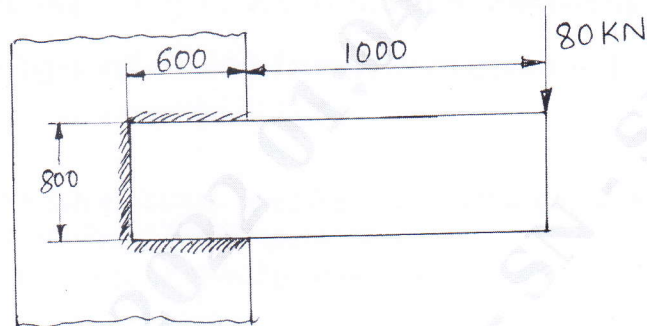

Fig.Q7(c)

(08 Marks)

- 8 a. Explain self locking and over hauling in power screw. (06 Marks)
- b. A square threaded power screw has a nominal diameter of 44 mm and a pitch of 7 mm with double start threads. The load on the screw is 6 kN and mean diameter of the thrust washer is 50 mm. Coefficient of friction for thread and collar is 0.12. Determine:
- (i) Torque required to raise the load.
 - (ii) Torque required to lower the load
 - (iii) Efficiency
 - (iv) Is the screw self locking type?

(14 Marks)

* * * * *